

**PICK-OFF TRANSFORMER****P3127****Features**

- \* 14.6mm seated height
- \* Vacuum encapsulated
- \* Compliant with EN 50020 and EN 60950

**Applications**

- \* Potentially explosive atmospheres
- \* Telecommunications
- \* Pick-off applications
- \* Telemetry
- \* Instrumentation

**DESCRIPTION**

P3127 is a high impedance transformer for applications where high performance and safety isolation to the most exacting international standards are required in a compact case size.

In conjunction with external protection (e.g. fuses, zener diodes, etc.) the device is compliant with EN 50020 for peak rated voltage  $\leq 375V$ .

P3127 has a turns ratio of 1.732:1 giving an impedance transformation of 3:1.

P3127 is designed for "listening" applications when placed across a line, presenting a very high impedance to minimize circuit loading. Signal performance is equivalent to ETAL® P1487.

## SPECIFICATIONS

### Electrical

At T = 25°C and as reference circuit Fig. 2 unless otherwise stated.

Parameter	Conditions	Min	Typ	Max	Units
Voltage isolation <sup>(1)</sup>	50Hz	3.88	-	-	kVrms
	DC	5.5	-	-	kV
Balance	DC - 5kHz Method TG25	50	-	-	dB
Input impedance	200Hz – 4kHz, Fig 2	20	-	-	kΩ
Operating range:	Ambient temperature				
Functional		-10	-	+70	°C
Storage		-40	-	+125	°C
Humidity		-	-	95	%R.H.

Lumped equivalent circuit parameters as Fig. 1

DC resistance, R <sub>DC</sub> <sup>(2)</sup>	Sum of windings (Corrected for ratio)	-	-	1860	Ω
Leakage inductance ΔL	Referred to pins 1-3	-	170	-	mH
Shunt inductance L <sub>p</sub>	-43dBm 200Hz	3.8	-	67	H
Shunt loss R <sub>p</sub>	-43dBm 200Hz	70	-	-	kΩ

### Notes:

1. Components are 100% tested at 6.5 kVDC.
2. Caution: do not pass DC through windings. Telephone line current, etc must be diverted using choke or semiconductor line hold circuit.

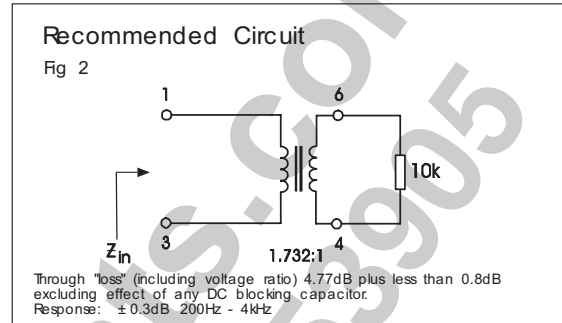
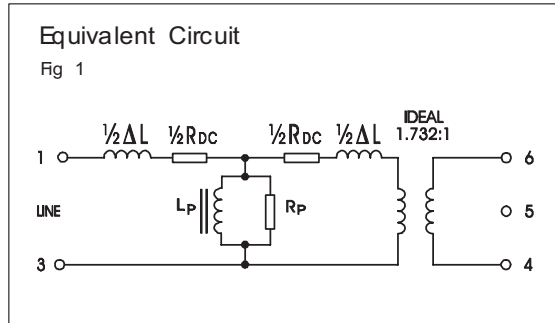

**CONSTRUCTION**

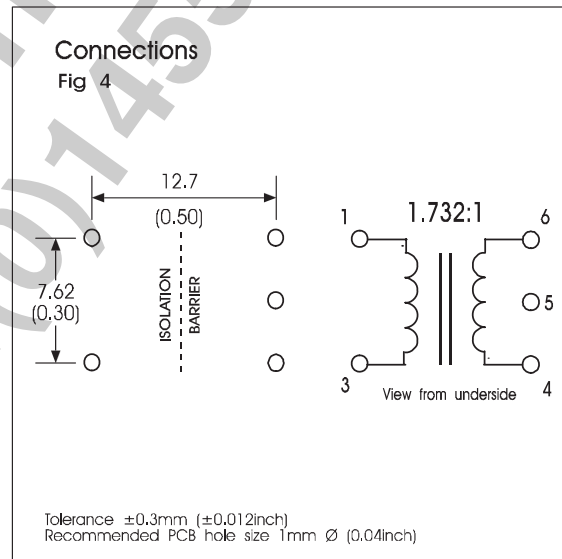
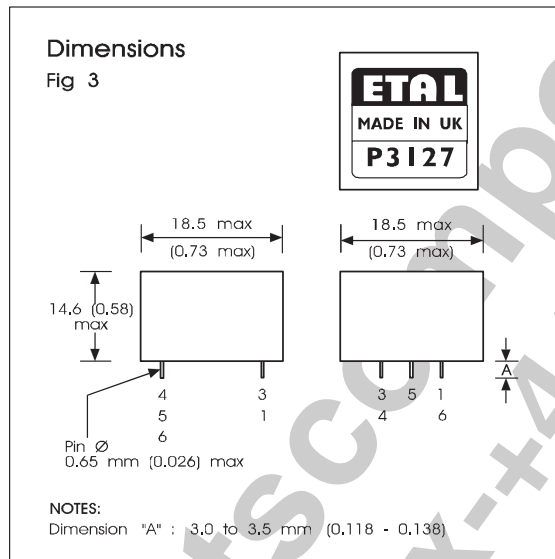

Dimensions shown are in millimetres (inches).  
Geometric centres of outline and pin grid coincide within a tolerance circle of 0.6mmØ.

EN 50020 para 7.1.2 Type 1(a) (side-by-side on separate slots of single piece moulding).

Fully vacuum encapsulated with hard epoxy resin totally enclosing all internal parts.

Critical Distances

- (a) Distance through bobbin dividing fillet. ≥1.0mm
- (b) Distance through bobbin walls to conductive core (Each winding). ≥0.5mm

- (c) Distance between highest point of each winding (including lead-outs) and top of dividing fillet. ≥1.0mm
- (d) Distance between highest point of each winding (including lead-outs) to conductive core through encapsulant. ≥1.0mm
- (e) Distance through potting box to conductive core. ≥0.7mm
- (f) Creepage/clearance (in air). ≥11.0mm

## ABSOLUTE MAXIMUM RATINGS

(Ratings of components independent of circuit).

Short term isolation voltage (15s)	4.6kVrms, 6.5 kVDC
DC current	100 $\mu$ A
Storage temperature	-40°C to +125°C
Lead temperature, 10s	260°C

## COPYRIGHT

ETAL and P3127 are Trade Marks of Profec Technologies Ltd.

The Trade Mark ETAL is registered at the UK Trade Marks Registry.

Profec Technologies Ltd. is the owner of the design right under the Copyright Designs and Patents Act 1988 and no rights or licences are hereby granted or implied to any third party.

© 1997 Profec Technologies Ltd.  
Reproduction prohibited

www.tscomponents.com  
Tel / Fax +44(0)1455 33995